

Quiz 5A	DL Sec	Grading:	
Last 6 digits of student ID:		Name:	First three letters of your family name

1. The circuit show on the right shows a circuit with a switch that is *initially* open. Every resistor in this circuit is a lightbulb with a resistance of $3\ \Omega$. Brief explanations are required for each part.

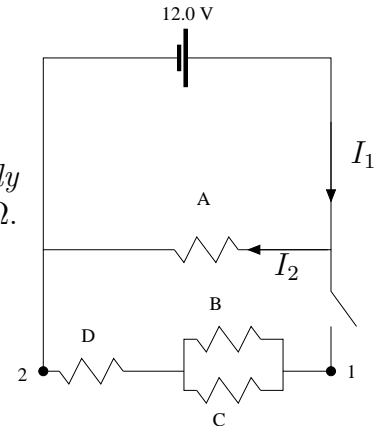

(a) While the switch is open, is $I_1 > I_2$, $I_1 = I_2$ or $I_1 < I_2$? Explain.

(b) The switch is then closed. Is I_1 bigger before or after the switch closes? Or does it remain the same? Explain.

(c) Is lightbulb *A* brighter or dimmer after the switch closes? Or does it remain the same? Explain.

(d) Rank the brightness of each of the bulbs when the switch is closed. If any are equal, be sure to indicate it explicitly.

Useful formulae: $\Delta V = \varepsilon - IR$, $P = \Delta V I$

(e) What is the voltage drop between points 1 and 2 i.e. What is $V_2 - V_1$? Is it bigger than, less than or equal to the voltage drop across lightbulb C ?

2. The decay of a sample of three different radioactive samples X , Y and Z are shown below. The time axis for each in years and cover the same, but the amount of radioactive material differs (note the change in the vertical axis) . Rank the half-lives from greatest to least.

